

OPERATING INSTRUCTIONS

GOAL GL1/M25

Mechanism /Seat Slide/Lumbar



Goal GL1/M25

Setting up a chair

Seat height

The Gas lift should be adjusted to ensure feet remain in contact with the floor or a footrest in order to provide stability.

Seat depth

To ensure correct thigh support and to prevent lower leg compression and associated restricted blood flow. A 3 finger gap should exist the front of the seat and the back of the knee.

Backrest / depth (where fitted)

Pneumatic lumbar adjustment to ensure the inward lumbar (lower back) curve is maintained, back muscles are supported and can relax. Also assists correct neck alignment.

Backrest / height

Slide adjustment to ensure correct, comfortable positioning for each individual user. Will assist with correct neck alignment while retaining the natural "S" shape of the spine.

Armrests (where fitted)

Should be primarily used to support the movement out of the chair. If required for certain job functions, the armrests should be adjusted to support the forearms when your side relaxes the shoulders and elbows. This will avoid strain in the neck and upper limbs.

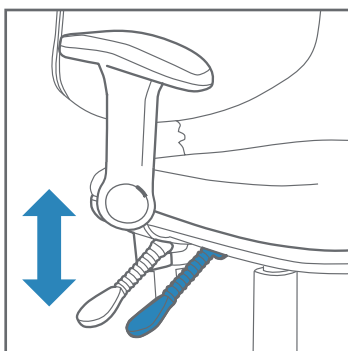

1. Seat height

Right front lever

This lever alters the height of the chair. By lifting the lever, the chair height can be increased or decreased. Once at desired height, release lever.

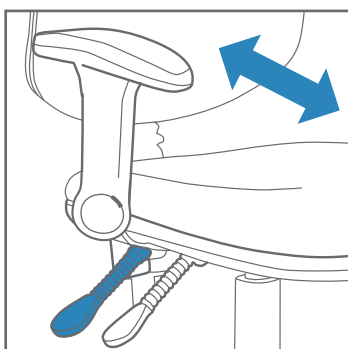

2. Back lock

Right-back lever

Lift the lever for the free-float operation of the back. Lower the lever to lock the back off in any position.

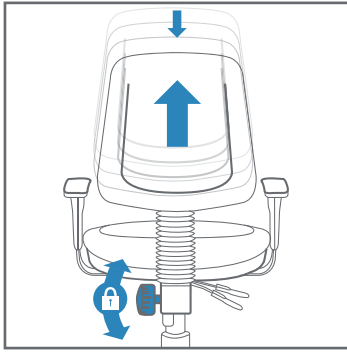

3. Back height adjustment

The back height is adjusted on a small hand-wheel located on the base of the back, on the left-hand side. Turn the hand-wheel to loosen the back, adjust the back to the required height then tighten the hand-wheel to secure.

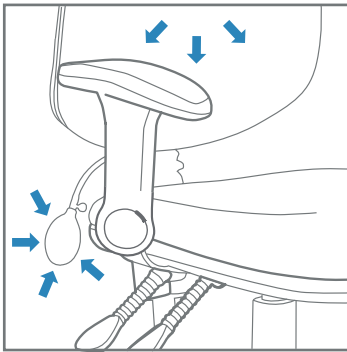

4. Inflatable lumbar support

To activate the lumbar support – locate the pump which hangs from the right-hand side at the bottom of the back when seated. Squeeze the pump at the end to inflate the lumbar in the back until comfortable support is achieved. To deflate the lumbar, there is a button at the top of the pump, when pressed in the lumbar will deflate.

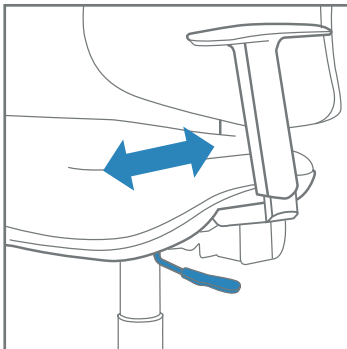

5. Seat slide

When seated, locate the lever on the left-hand side underneath the seat pan. To operate lift the lever and slowly move the seat forward until the desired depth is reached. Release the lever to lock the seat in position. The seat slide allows the depth to be adjusted up to an additional 50 mm.

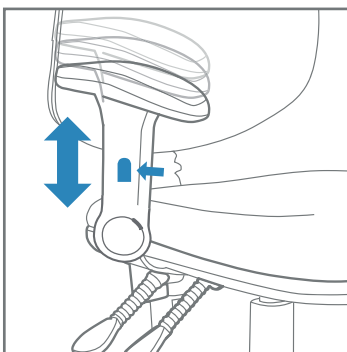

6a. Height adjustable arm (AM)

To adjust the height of the arm locate the silver button on the centre of the arm column. Please note each arm needs to be adjusted individually.

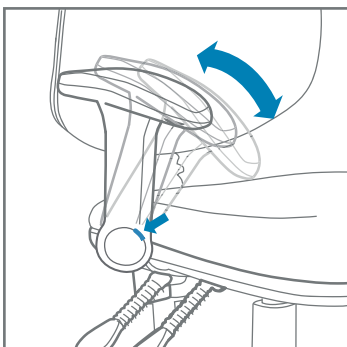

6b. To drop the arms away (AM)

To drop the arms away from the chair find the base of the arm, press the small black button at the top of the chrome disk. Once pressed, you will be able to fold the arms away from the chair. Please note each arm needs to be adjusted individually.



FM36814 EMS537195



Ocee Design
Design House, Caswell Road
Brackmills Industrial Est.
Northampton, NN4 7PW

t. 01604 674674
f. 01604 674673
www.oceedesign.com
sales@oceedesign.com

@oceedesign
@OceeDesign